

THE NEW L SERIES

SINGLE STAGE IN-LINE PUMPS



IE2
HIGH EFFICIENCY

IE3
PREMIUM EFFICIENCY

ErP
COMPLIANT

SAER
ELETTOPOMPE

THE NEW RANGE L

Whether you are looking for a quiet solution or resistance to high temperature for your HVAC applications, SAER's new L series is the answer. An in line pump, characterized by innovative compact design to save space, combined with special nodular engineering cast iron construction which ensures constant performance over time even under harsh conditions. Made in Italy. Quality guaranteed.

● STRONG.

manufactured with robust nodular cast iron construction for temperatures up to 140°C. Stainless steel shaft as a standard. Close coupled design to save space and reduce noise levels. Flange ratings from PN 25 up to DN 50, PN16 from DN 65 to DN150. Operating pressure 16 bar.

SICURA.

ingombri limitati grazie alla configurazione monoblocco per un'installazione semplice, silenziosa e conveniente. Albero in acciaio inossidabile di serie. Le parti in pressione sono realizzate in ghisa sferoidale, rendendola la scelta ideale per funzionamento con liquidi sino a 140°C. Pressione di esercizio: PN16 di serie (PN25 a richiesta per grandezze fino a DN50).

● ADVANCED.

Compact in line design for simple installation and reduced overall dimensions. A wide range to meet any need: 27 types, sizes from DN 32 up to DN 150, from 0,37 up to 75 kW, 50 and 60 HZ, 2 and 4 pole.

ADATTABILE.

con una gamma di 27 tipi e svariate opzioni disponibili (diverse tipologie di tenute meccaniche e materiali) troverete risposta alle vostre esigenze; grandezze da DN 32 fino a DN 150, potenze da 0,37 fino a 75 kW, 50 e 60 HZ, 2 e 4 poli.

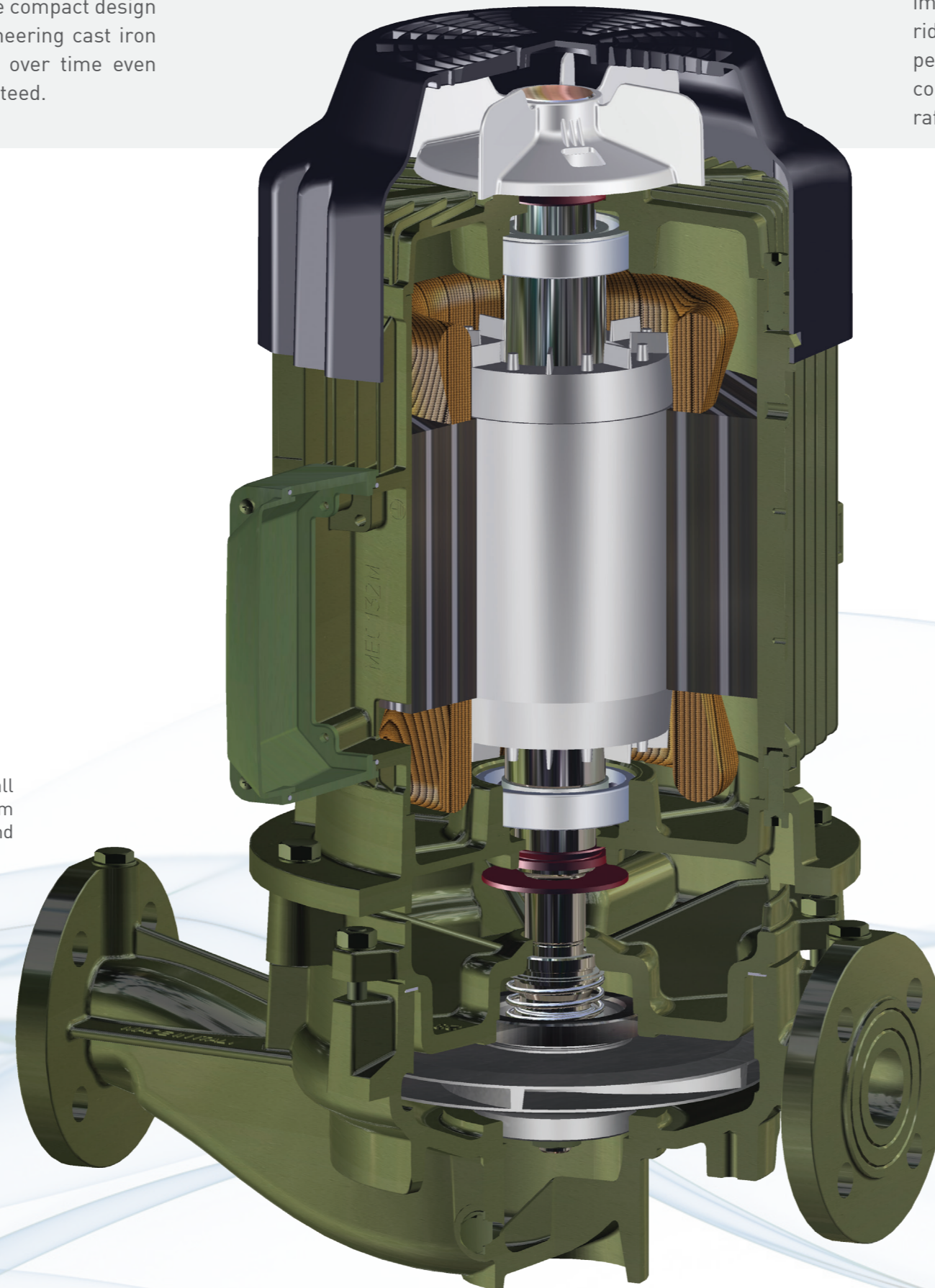

LA NUOVA GAMMA L

Per i vostri impianti di climatizzazione la nuova serie SAER L è la risposta adeguata laddove cerciate silenziosità combinata ad una resistenza imbattibile alle elevate temperature. L sono pompe in line caratterizzate da ridotte dimensioni di ingombro e prodotte in ghisa sferoidale assicurando performances costanti nel tempo ed elevata affidabilità anche in condizioni gravose, trovando applicazione in impianti di condizionamento/raffreddamento sia civili che industriali. Made in Italy. Qualità garantita.

● ENERGY SAVING.

ErP compliant for dramatically reduced operating costs. Motor efficiency class IE2 and IE3, version integrated inverter up to 15 kW. High performances CFD hydraulic design with MEI > 0,7 for most of the models. Optimized geometry to avoid turbulence and increase energy efficiency.

ENERGY SAVING.

conforme alla direttiva ErP per ridurre i costi di esercizio. Motori in classe di efficienza IE2 and IE3, possibilità di variatore di frequenza integrato a bordo motore fino 15 kW. Prestazioni idrauliche con Minimum Efficiency Index (MEI) > 0,7 per la maggior parte dei modelli. Geometria ottimizzata con sistemi CFD, dando una macchina altamente efficiente.

● RELIABLE.

wide selection of materials and mechanical seals for different applications (heating, cooling, civil, industrial, water supply etc...). Impeller available in cast iron, marine bronze and cast stainless steel AISI316.

RESISTENTE.

elevata qualità e varietà dei materiali selezionati la rendono adattabile a diverse applicazioni (riscaldamento, condizionamento, civile, industriale, approvvigionamento acque ecc.). Le giranti sono disponibili sia in ghisa che bronzo marino e acciaio inossidabile AISI 316. Test di laboratorio condotti per offrire una soluzione anche per le condizioni di lavoro più estreme.

VERSION EQUIPPED WITH FREQUENCY CONVERTER

VERSIONE CON VARIATORE DI FREQUENZA



THE USE OF THE FREQUENCY CONVERTER (INVERTER) HAS MANY BENEFITS FOR USERS:

Energy saving.

- Reduced LCC (life cycle cost).
- Low environmental impact thanks to lower power consumption.
- Less wear of mechanical components.

MAIN FUNCTIONS:

- Operation at constant differential pressure, reading via two transducers;
 - Versions for operation at constant pressure thanks to the pressure transducer supplied as standard;
 - Drive with the main protections (current, voltage, dry running).
 - Working as a team (master / slave) for multi pump systems.
- Frequency changers IVT series, that can be installed on the motor, are available in three-phase version up to 15 kW and IVM series, the single-phase version, up to 2,2 kW.

L'USO DEL VARIATORE DI FREQUENZA (INVERTER) PORTA A DIVERSI VANTAGGI PER L'UTILIZZATORE:



- Risparmio energetico.
- Ridotti LCC (costi di vita del prodotto).
- Basso impatto ambientale grazie al ridotto assorbimento di potenza.
- Minore usura dei componenti meccanici.

FUNZIONI PRINCIPALI:

- Funzionamento a pressione differenziale costante, la lettura è effettuata attraverso due trasduttori.
- Versione per utilizzo a pressione costante tramite il trasduttore di pressione fornito come standard.
- Inverter dotato delle principali protezioni (corrente, tensione, marcia a secco).
- Funzionamento master / slave per sistemi multipompa.
- I variatori della serie IVT, installabili direttamente sul motore, sono disponibili nella versione trifase fino a 15 kW. Quelli della serie IVM, versione monofase, fino a 2,2 kW.

MATERIALS OF CONSTRUCTION

MATERIALI DEI COMPONENTI PRINCIPALI

COMPONENT/ Componente	MATERIAL / Materiale	MATERIAL / Materiale	
		STANDARD	ON REQUEST / A richiesta
PUMP BODY Corpo pompa		NODULAR CAST IRON Ghisa sferoidale EN-GJS-500	
SEAL HOLDING DISC Disco portatenuta		NODULAR CAST IRON Ghisa sferoidale EN-GJS-500	
IMPELLER Girante		CAST IRON Ghisa EN-GJL-250	PRECISION CASTED STAINLESS STEEL Acciaio inossidabile microfuso AISI316 (CF8M - 1.4408) Bronze Bronzo G-CuSn10
SHAFT END Sporgenza albero		STAINLESS STEEL Acciaio inossidabile AISI431 (1.4057)	STAINLESS STEEL Acciaio inossidabile DUPLEX 1.4362
MECHANICAL SEAL Tenuta meccanica		GRAPHITE / SILICON CARBIDE / EPDM	SILICON CARBIDE / SILICON CARBIDE / FPM
RUBBER PARTS Parti in gomma		EPDM	FPM

MOTORS

- Asynchronous induction with external ventilation (TEFC) motors. Protection: IP55 - Insulation: class F
- All the coupled motors are in conformity with Directive 2009/125/EC (ErP) - Regulation (EC) No 640/2009 and (EU) No 4/2014. They are available in different efficiency classes according to IEC 60034-30.
- Standard: motor suitable for VFD (inverter) operations up to 45 kW.
- On request, version with VFD (inverter) integrated on the motor up to 15 kW

MOTORI

- Asincroni a induzione con ventilazione esterna (TEFC). Protezione: IP55 - Isolamento: classe F
- Motori conformi alla Direttiva 2009/125/EC (ErP) - Regolamento (EC) No 640/2009 e (EU) No 4/2014. I motori sono disponibili in diverse classi di efficienza in accordo a IEC 60034-30.
- Motori in versione standard fino a 45 kW, idonei all'uso con variatore di frequenza.
- A richiesta, versioni con inverter a bordo motore fino a 15 kW.

A COMPLETE RANGE

GAMMA COMPLETA

L- 2P - 50 HZ

- Up to 60 different models, from DN32 up to DN 100.
- Power: from 1,5 kW up to 45 kW. Single phase version available up to 4 kW.
- Capacity up to 320 m³/h, Head up to 9 bar.

L- 4P - 50 HZ

- Up to 65 different models, from DN32 up to DN 150.
- Power: from 0,37 kW up to 45 kW;
- Capacity up to 320 m³/h, Head up to 9 bar.

L- 2P - 50 HZ

- Sino a 60 modelli differenti, da DN32 sino a DN 100.
- Potenza: da 1,5 kW sino a 45 kW. Versione monofase disponibile sino a 4 kW.
- Portata massima 320 m³/h, prevalenza massima 9 bar.

L- 4P - 50 HZ

- Sino a 65 modelli differenti, da DN32 a DN 150.
- Potenza: da 0,37 kW sino a 45 kW;
- Portata massima 320 m³/h, prevalenza massima 9 bar.

6L- 2P - 60 HZ

- Up to 52 different models, from DN32 up to DN 100.
- Power: from 1,5 kW up to 45 kW;
- Capacity up to 320 m³/h, Head up to 9 bar.

6L- 4P - 60 HZ

- Up to 60 different models, from DN32 up to DN 150.
- Power: from 0,37 kW up to 45 kW;
- Capacity up to 320 m³/h, Head up to 9 bar.

6L- 2P - 60 HZ

- Sino a 52 modelli differenti, da DN32 a DN 100.
- Potenza: da 1,5 kW a 45 kW;
- Portata massima 320 m³/h, prevalenza massima 9 bar.

6L- 4P - 60 HZ

- Sino a 60 modelli differenti, da DN32 a DN 150
- Potenza: da 0,37 kW a 45 kW;
- Portata massima 320 m³/h, prevalenza massima 9 bar.

1450 1/min

TYPE TIPO	Q(m ³ /h)	H(m)
L32-125S	5÷13	6÷3
L32-160S	5÷13	9÷6
L32-200	5÷15	15÷10
L32-250	5÷30	21÷14
L40-125S	10÷30	6,5÷2
L40-160N	10÷25	9÷5
L40-200N	8÷22	14÷11
L40-250N	10÷35	20÷7
L50-125	10÷30	6÷4
L50-160N	15÷35	9÷7
L50-200S	15÷45	14÷10
L50-250N	15÷40	22÷17
L65-125S	20÷60	6÷4
L65-160	25÷65	10÷6
L65-200N	25÷80	15÷11
L65-250N	25÷80	22÷16
L80-160	30÷80	9÷7
L80-200	50÷100	13÷11
L80-250	60÷140	23÷18
L80-315	70÷170	34÷26
L100-200	80÷180	14÷9
L100-250	100÷220	23÷12
L100-315	120÷290	35÷20
L125-250	150÷350	22÷10
L125-315	150÷400	37÷22
L150-315	250÷550	36÷20
L150-400	250÷580	58÷35

1750 1/min

TYPE TIPO	Q(m ³ /h)	H(m)
L32-125S	6÷16	8,5÷4
L32-160S	6÷16	13÷8
L32-200	6÷18	21÷14
L32-250	6÷36	30÷20
L40-125S	12÷36	9÷3
L40-160N	12÷30	13÷7
L40-200N	10÷26	20÷15
L40-250N	12÷42	29÷10
L50-125	12÷36	9÷6
L50-160N	18÷42	13÷10
L50-200S	18÷53	20÷14
L50-250N	18÷48	32÷24
L65-125S	24÷72	9÷6
L65-160	30÷80	15÷9
L65-200N	30÷95	21÷16
L65-250N	30÷95	32÷23
L80-160	36÷95	13÷10
L80-200	60÷120	19÷16
L80-250	70÷170	33÷26
L80-315	85÷200	49÷37
L100-200	95÷215	20÷13
L100-250	120÷260	33÷17
L100-315	145÷350	50÷29
L125-250	180÷420	31÷14
L125-315	180÷480	53÷31
L150-315	300÷660	52÷29
L150-400	300÷700	83÷50

2900 1/min

TYPE TIPO	Q(m ³ /h)	H(m)
L32-125S	10÷25	25÷14
L32-160S	10÷25	37÷27
L32-200	10÷30	60÷40
L32-250	10÷50	90÷68
L40-125S	15÷50	27÷16
L40-160N	15÷45	38÷24
L40-200N	15÷50	55÷39
L40-250N	15÷60	82÷46
L50-125	20÷60	23÷18
L50-160N	30÷80	37÷26
L50-200S	30÷90	57÷33
L50-250N	30÷80	88÷70
L65-125S	40÷130	24÷13
L65-160	50÷130	39÷28
L65-200N	50÷150	60÷48
L65-250N	50÷130	88÷77
L80-160	90÷170	36÷29
L80-200	100÷240	52÷38
L100-200	140÷320	58÷35

3500 1/min

TYPE TIPO	Q(m ³ /h)	H(m)
L32-125S	12÷30	36÷20
L32-160S	12÷30	53÷38
L32-200	12÷35	86÷57
L40-125S	18÷60	38÷23
L40-160N	18÷55	54÷34
L40-200N	18÷60	79÷56
L50-125	25÷70	33÷25
L50-160N	35÷95	53÷37

TYPE TIPO	Q(m ³ /h)	H(m)
L50-200S	35÷110	82÷47
L65-125S	50÷155	34÷18
L65-160	60÷155	56÷40
L65-200N	60÷180	86÷69
L80-160	110÷200	51÷41
L80-200	120÷180	74÷59
L100-200	160÷380	83÷50



 Made by **italians**

 SAER.Elettropompe -  @saerelettropompe -  Saer Elettropompe -  Saer Elettropompe

 SAER Pump Selector  



SAER[®]
ELETTROPOMPE

SAER ELETTROPOMPE S.p.A.

Via Circonvallazione, 22 - 42016 Guastalla (RE)
Italy Tel. +39 0522 830941 - Fax +39 0522 826948
E-mail: info@saer.it - www.saerelettropompe.com



SAER is an ISO 9001 certified company.

SAER can alter without notifications the data mentioned in this catalogue. Performances and tolerances according to UNI EN ISO 9906:2012 – Grade 3B

La ditta si riserva la facoltà di modificare senza preavviso i dati riportati in questo catalogo. Prestazioni e tolleranze secondo UNI EN ISO 9906:2012 – Grado 3B